

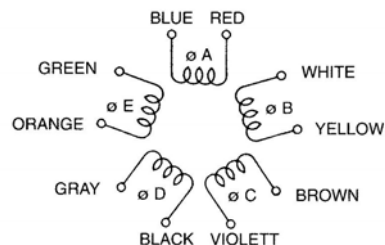

SECM599er Baureihe

5-Phasen-Schrittmotor
[0,72° High-Torque-Version]

Model	Full Step Angle	Holding Torque (Ncm)	Current/Phase (A)	Resistance/Winding (Ω)	Inductance/Winding (mH)	Voltage DC (V)	Torque/Speed
A = Single Shaft B = Double Shaft							
SECM 599 - T 1.4 A SECM 599 - T 1.4 B	0.72°	410	1.40	2.7	18.7	3.8	①
SECM 599 - T 2.8 A SECM 599 - T 2.8 B	0.72°	410	2.80	0.67	4.3	1.9	①
Number of Leads	Weight (Kg)		Size Length (mm)		Rotor Inertia (Kgcm ²)		
10	3.0		86x86x96.5		2.0		

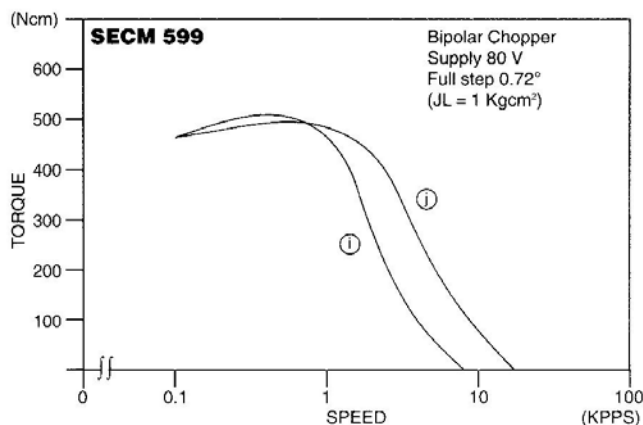
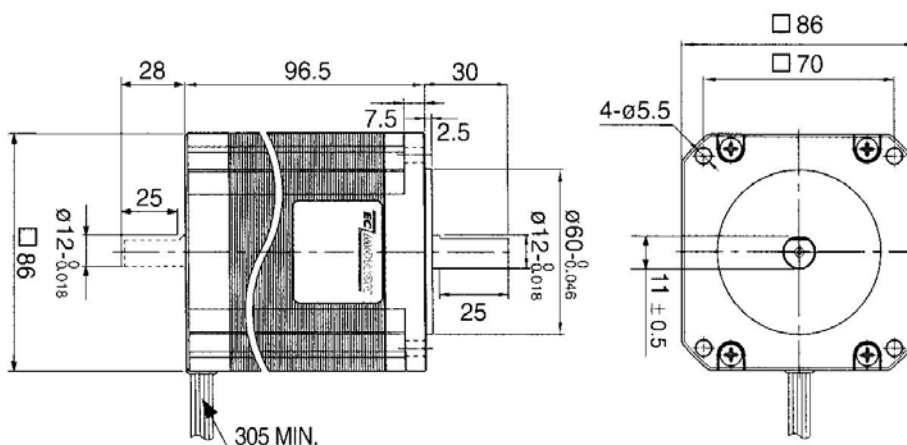

Optional sind für unsere Schrittmotoren Encoder und / oder Planetengetriebe erhältlich.