

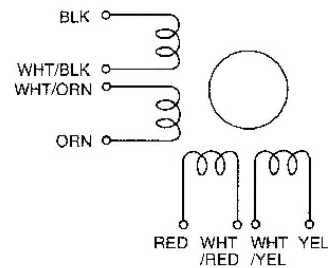

ECM296er Baureihe

2 Phasenschrittmotor
[1,8° Standard-Version]

Model		Unip Bipo	Holding Torque (Nm)	Current /Phase (Amps)	Resistance /Winding (Ohms)	Inductance /Winding (mH)	Number of Leads	Weight
Single Shaft	Double Shaft							Rotor Inertia
ECM296-E4.2A	ECM296-E4.2B	X	1.3	4.2	0.46	1.6	8	1.5 Kg 670 gcm ²
ECM296-E4.2A	ECM296-E4.2B	X	1.7	5.9	0.23	1.6		

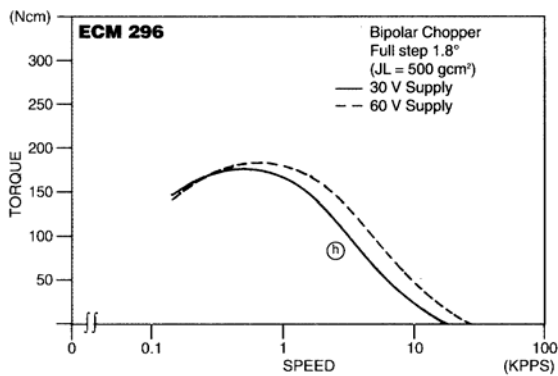
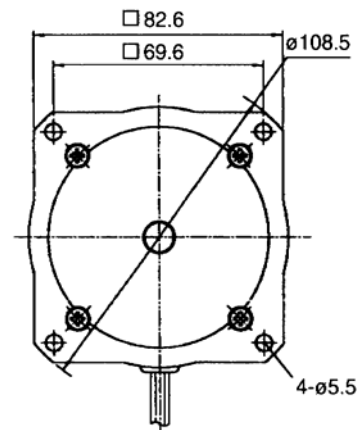
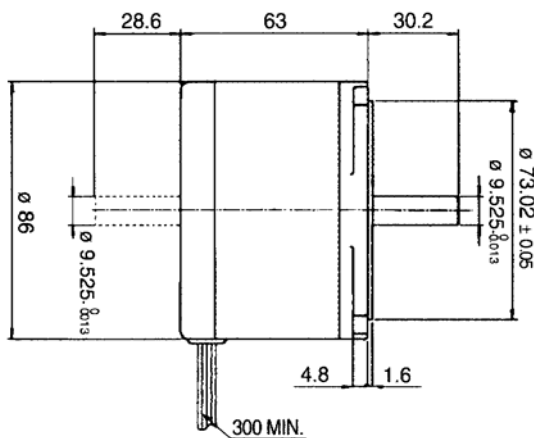

Optional sind für unsere Schrittmotoren Encoder und / oder Planetengetriebe erhältlich.



EC Motion GmbH - Auf den Steinen 20 - 41812 Erkelenz
Tel.: +49 (0)2164-7014-0 - Fax. : +49 (0)2164-701419
Internet: www.ec-motion.de - e-mail: info@ec-motion.de

